

Tele : 0532-2420772
E-mail : armyschoolalld@gmail.com

Army Public School
New Cantt, Allahabad- 211001

5077/ATL

30 Oct 2022

M/S -----

INVITATION OF TENDER
CONSTRUCTION OF ATL LAB OF SINGLE STOREY (SHEET
ROOFING) AT ARMY PUBLIC SCHOOL, NEW CANTT ALLAHABAD.

1. You are invited by the Management of Army Public School, Allahabad to submit Tender for the above mentioned work described in the accompanying documents.
2. Your tender duly completed may be put in the tender box kept in school administrative block on or before **21 Nov 2022** together with all relevant documents sealed in an envelope duly quoted your rates.
3. The following documents are included with this tender invitation:-
 - (a) Part I – General Information about the Tender.
 - (b) Part II – Technical Bid.
 - (c) Part III – Price Bid.
 - (d) Part IV – Terms & Conditions.
 - (e) Part V– Specifications of Building Work.
 - (f) Part VI – Drawings of the Class Rooms.
4. The Management of Army Public school, Allahabad doesn't bind itself to accept the lowest nor any tender and may cancel tendering process at any time.
5. Wherever there is difference between specifications and drawings, specifications will supersede the drawings.



Signature of Contractor

Signature of Principal
Army Public School, New Cantt Allahabad

PART I – GENERAL INFORMATION ABOUT THE TENDER

Sl.No.	Tender for the work of	Construction of ATL LAB of single storey (Sheet Roofing) at Army Public School, New Cantt , Allahabad.
1.	Earnest Money Deposited	Rs. 2.5% of total project cost. Bank draft to be made in favour of Army Public School New Cantt, Allahabad.(Refundable)
2.	Date of Issue of Tender	01 Nov 2022 to 21 Nov 2022 (to be downloaded from school website-www.armypublicschoolalld.org)
3.	Last Date of Receipt of Tender	21 Nov 2022
4.	This Tender Contains	19 pages and Drawings Sheets
5.	Time allotted for work	Two months from date of issue of work order
6.	Site of the Work	Army Public School, New Cantt, Allahabad.
7.	Tender Cost	Rs. 500/-(Rupees five hundred only). Bank draft to be made in favour of Army Public School New Cantt, Allahabad(Not refundable)

Signature of Contractor

Signature of Principal
Army Public School, New Cantt Allahabad

1.	Name of the firm	
2.	Address of the head/ registered / branch office	
3.	Phone no.	
4.	Fax no.	
5.	Mobile no.	
6.	PAN NO.	(Enclose Proof)
7.	GSTN NO.	(Enclose copy of GSTN No. Registration)
8.	Registered with govt. agencies	(Enclose Proof)
9.	Your bank account no.	
10.	Name & address of bank	
11.	Category of trade	
12.	Name of the partners / proprietor	
13.	Experience in years in the respective trade(attach work orders executed in past two years)	
14.	Single work order during the last two financial years	
15.	Payment details (earnest money)	Draft no.date..... Amount Issuing bank name and branch

CERTIFICATE

In consideration of my being contractor, I hereby agree that I shall not withdraw, amend or attach any conditions to my tenders submitted to the school authorities before **21 Nov 2022** from the date of issuing work order. Said tenders of acceptance, and I do so, the Principal Army Public School, New Cantt, Allahabad shall be entitled to forfeit our earnest money deposit along with the tender and remove us from the school work contract without prejudice to any other right or remedy by school for such breach on our part.

DECLARATION

I (Proprietor/ Partner/Manager) do here by declare that the entire declaration made in the application form is true to the best of my knowledge. [NOTE: - If there any changes in the construction of working of firm, the affecting accuracy of the answer now given, should be promptly communicated to The Principal, Army Public School New Cantt Allahabad.

Date :
Place :

Signature of Contractor
With rubber stamp

PART II – TECHNICAL SPECIFICATIONS
CONSTRUCTION OF ATL LAB OF SINGLE STOREY (SHEET ROOFING)
AT ARMY PUBLICSCHOOL, NEW CANTT ALLAHABAD

Sl. No	ITEMS OF WORKS
1.	Excavation of foundation trenches of required size and shape with all tools and plants for proper completion of work as per the drawing, details & specification.
2.	Providing & applying anti termite treatment in foundation trenches, Plinth, Apron etc. as per the drawing, details & specification by the Architect.
3.	Providing & Preparation of foundation bed of required size and shape in PCC 1:4:8 type D-2 (1 Cement: 4 course sand: 8 – 40 mm size stone Aggregate) as per the drawing, details & specification.
4.	Providing and cutting bending and placing fixing of all types of mild steel TMT reinforcement bars for foundation, columns, all types of beams, slabs, Chajjas etc. as per the drawing, details & specification.
5.	Providing and casting of 40 mm thick D.P.C. with recommended water proof chemical in PCC 1:2:4 type B-0 as per the drawing, details & specification.
6.	Providing, Preparation and casting of all type of R.C.C. work in M-25 concrete (design mix) for the foundations, Beams, Columns, Slabs, Chajjas etc. with all tools and plants for proper completion of work, as per the drawing, details, direction and specification.
7.	Provide and construct 230 mm thick wall with 1:6 cement & sand mortar and 115mm thick brick wall with 1:4 cement & sand mortar in first class locally available bricks, where required as per the drawing, details, direction and specification.
8.	Providing and fixing mild steel angle 40X40X6 mm door frame with 35mm thick waterproof ISI marked flush door of approved brand with all fixture and fasteners as per the drawing, details, direction and specification.
9.	Providing and fixing windows of sliding type made of Color Coated Galvanized Steel or color Coated Aluminum Windows with 8mm thick Square bar mild steel or aluminum grill. And 5mm thick clear transparent glass fixed and stainless steel fly/mosquito proof jali as per the drawing, details, direction and specification.
10.	Supply and fixing of 35 mm thick factory made standard quality (ISI) flush doors with complete iron fittings of ISI marked heavy quality and Wooden Cabinets as per as per the drawing, details, direction and specification.
11.	Providing, preparation and fixing all types of form work, shuttering, scaffolding, centering with required tools, plants and shuttering material for proper completion of work as per the drawing, details, direction and specification.

 Signature of Principal
 Army Public School
 New Cantt Allahabad

Signature of Contractor

12.	Providing and plastering in CM 1:6 cement & sand mortar plaster work in interior and exterior wall surfaces, columns, beams and ceiling surfaces with all tools & plants for proper completion of work as per the drawing, details, direction and detailed specification.
13.	(a) Vitrified Ceramic tiles 10 mm thick (square/ rectangular) polished, area of each tiles not exceeding 0.36 sqm, in floors etc. set and jointed in floors etc. set and jointed in neat cement slurry and pointed in white or colored cement to match. As per the drawing, details, direction and details specification.
14.	<p>(a) Fabrication, Supply & Fixing truss work / M.S. pipe as per design, purlins, rafters and trusses complete with priming , painting and fixing all complete.</p> <p>(b) Supply and fixing of color coated Aluminum –Zinc Alloy coated steel (Aluminum –around 55% & Zinc -43%) rib profile sheets of 0.50 mm thick (TCT) having effective width 1000 mm +/- 10 mm, crest 25-32 mm and 200-250 mm pitch C/c with male female side laps and anti-siphoning features at male end, minimum Yield strength 550 MPA and confirming standards AS 1397 , ASTM A 792 in approved color and make including accessories such as Gutter Flashing, ridge pieces, barge boards, Crimped curves and with nylon coated self-tapping / self-drilling screws with EPDM washers etc., all works complete as per drawings, specifications and instructions of Engineer in charge . Rate includes cost of all materials against supply, Carriage Erection, Installation for roofing at all heights upto 13.00 m above from Ground level , labor, tools & plants and all other incidental charges etc complete. (Payment will be done on covered area basis) as per the design, drawing, direction and details specification.</p>
15.	<p>a. Fixing of Electrical Fans, Tube lights, Exhausts, Ceiling Lights or other Light fixtures of standard quality make- Havels, Orient, Bajaj as per approved by the Architect and as per the electrical design, details, direction and detailed specification.</p> <p>b. Providing and fixing of electrical Concealed 25mm dia P.V.C. conduits in slab, walls for electrical circuit wiring as per the electrical design, details, direction and details specification.</p> <p>c. Providing and fixing of modular switch board boxes of approved size, shape and make at required location with proper finishing as per the electrical design, details, direction and details specification.</p> <p>d. Providing, fixing and laying of modular electrical switch and multistand cooper wiring of approved make-Havels, RR cable, or standard, design, colour and size as per electrical design, details, and directions and detail specification.</p> <p>e. Providing laying, connection distribution board with outdoor main electrical supply as per electrical design, details, and directions and detail specification.</p> <p>f. Providing 3 phase electrical connection from overhead main line.</p> <p style="text-align: right;"> Signature of Principal Army Public School New Cantt Allahabad</p> <p>Signature of Contractor</p>

16.	<p>a. Providing and painting of all exterior wall surfaces, ceiling and chajjas etc with super snowcem cement colour and all interior wall surface ceiling with all interior wall surface & ceiling with Oil bound distemper of approved colour, shade, and texture with all tools plants etc for proper completion of work as per details, design, pattern, directions and detail specification.</p> <p>b. Providing and application of synthetic enamel paint of approved colour shade and make on M.S. angle door frame windows, grill flush door etc. as per details, design, pattern, directions and detail specification.</p> <p>c. Makes of OBD : Asian / Berger/ Nerolac.</p> <p>d. Make of Snowcem : Asian / Berger/ Nerolac.</p> <p>e. Make of Synthetic enamel paint : Asian / Berger/ Nerolac.</p>
17.	<p>a) Providing and fixing 100 mm dia P.V.C. rain water pipe at given position on as per details, directions and detail specification of make :Fenolux/ Prince/ Supreme.</p> <p>b) Providing and constructing inspection chamber in required No. and size at recommended location as per details, drawing, directions and detail specification.</p>
18.	Supply of fixing Green Boards due in each class room of standard size (size to be approved by Principal APS New Cantt Allahabad at the time of execution of work).
19.	All construction work as per details, drawing, directions and detail specification.
20.	Providing and construction 750 mm wide Plinth Protection with PCC 1:3:6 type C-2 all around the building (Apron) of required size as per details direction and specification.
21.	<p>(a) Providing and laying 3 meters wide interlocking tiles approach path at both end of building connected to inside campus road.</p> <p>(b) The make design, color, shape, pattern of Interlocking tiles shall be approved by Architect or Engineer in charge and confirming I.S. Code.(if required)</p>

Signature of Contractor



Signature of Principal
Army Public School
New Cantt Allahabad

PART III –PRICE BID**CONSTRUCTION OF ATL LAB SINGLE STOREY (SHEET ROOFING) AT ARMY PUBLIC SCHOOL, NEW CANTT ALLAHABAD**

S. No.	Particulars	Unit	No of unit required	Rate per unit	Total amount
1.	Construction of 01 Temp ATL Lab room of single storey (Sheet Roofing) at Army Public School, Allahabad as per details and specifications shown in the drawings. Size 60 ft x 25 ft with Verandah	Job	1	Rs. _____ Rupees _____ _____ _____ _____	Rs. _____ Rupees _____ _____ _____ _____

Defect Liability Period:-

1. The defect liability period for the job is **one year** from date of completion of work. The Contractor shall be liable to repair any defect noticed during defect liability period without payment of any extra cost to school. The Contractor shall be responsible to attend the defect within 15 days from notice given in writing, failing which the defects will be rectified through another agency at the risk and cost of the Contractor and amount recovered from the Performance Guarantee.

2. 5% of the total contract amount as **Performance Guarantee** will be kept reserve towards defects, if any observed, and will be released on successful completion of **Defect Liability Period**.

Signature of Contractor



 Signature of Principal
 Army Public School
 New Cantt Allahabad

PART IV – TERMS AND CONDITIONS
(GENERAL INFORMATION, INSTRUCTIONS AND CONDITIONS APPLIED)

1. Last date and time for issue/depositing this Tender is **21 Nov 2022**. Tender Bids received after this date and time even by post/ courier will not be entertained.
2. Sealed Bids by authorized contractor should be dropped in the Tender Box. No. responsibility will be taken for postal delay or non-delivery/ non receipt of Bid documents. Bid sent by FAX or e-mail will not be considered. If the tenderer withdraws the tender before the said period or issue of letter of acceptance whichever is earlier or makes modifications in the terms & Condition of the tender which are not acceptable to the competent authority then the competent authority will be at liberty to forfeit 50% of the said earnest money.
3. **Location of the Tender Box.** Principal's Office Corridor.
4. **Forwarding of Bids.** Bids should be forwarded by contractors on the prescribed format attached with the tender separately as technical and price bids. The technical bid should include the following details:-
 - (a) Technical Specifications.
 - (b) GSTN Number
 - (c) Bank Account No.
 - (d) Bank Address
 - (e) Complete Postal Address of Office.
 - (f) Office Landline and Mobile Phone Nos.
 - (g) E-mail Address of office (Optional).
5. **Rejection of Bids.** Canvassing by the Contractors in any form, Unsolicited letter and post tender correction may invoke summary rejection with forfeiture of Earnest Money Deposit(EMD) conditional tenders will be rejected.
6. **Validity of Bids.** The Bids should remain valid for 90 days from the date of submission of bids.
7. **Earnest Money Deposit.** The tenderers' have to submit **2.5% of project cost** in the form of Bank Draft in favour of " ARMY PUBLIC SCHOOL, NEW CANTT, ALLAHABAD" payable at Allahabad as EMD. The unsuccessful Contractors will be returned to them without any interest at the earliest on or before the 30th day after the award of the contract.
8. **Architectural,** structural drawings and consultancy charges will be deducted from the contractor's payment **@ 1.42%** of total cost of project. These charges will be deducted from each bill of the contractor.
9. All the Tax will be deducted at the time of any payments as per defined/ eligible tax rate and authority will give proper documents of depositing the same amount to contractor/ suppliers.
10. The tenderers have to quote their rates both in figures and words. The rates quoted in the tender should be inclusive of all freight, taxes, service tax, GST and other incidental charges if any (i.e. F.O.R. School campus).



Signature of Principal

Army Public School
New Cantt Allahabad

Signature of Contractor

11. Every page of the tender should be signed (full signature) and rubber stamped by the tenderer. It should also be signed wherever there is overwriting and cutting.
12. All works services will be according to specification as per tender paper or subject to approval by the Board of Officers.
13. The successful contractor is solely responsible for the materials and labour necessary for the completion of work.
14. The Contractor is responsible for periodic cleaning of the site during the construction process and removal of all construction material and debris at all time necessary, during and at the end of construction period.
15. The Contractor is responsible for ensuring all safety and security measure to be adhered to on site during the construction process including the safety of all students, staff and workmen along with the security of the site. Contractor will ensure that necessary screens are erected at work site to segregate the construction area from the school premises and ensure no access to students at the site of construction during the construction phase.
16. The Contractor is required to ensure that measures are put in place to mitigate against all potential social and environmental impacts that can arise as a result of the use of equipment and machinery associated with the construction of the project.
17. The Contractor shall be deemed to have examined all documents, conditions of contract and to have acquainted himself with the detailed descriptions of the work to be done and the way in which they are to be carried out.
18. The Contractor shall be deemed to have visited the site before preparing his tender and to have examined for himself the conditions under which the works will processed and all other matters affecting the carrying out the work and cost thereof.
19. The Contractor will maintain records of minimum wages to their labour any dispute in this regards will be dealt with directly by him and not by the school.
20. The tender forms will be issued to the interested parties only after receipt of application for issue of tender from Contractor and after satisfying the credentials of the person/ party.
21. The Contractor, whose tender is accepted, will be required to furnish performance guarantee of five percent (5%) of the tendered amount and a sum @5% of the gross amount of the bill shall be deducted from final bill and will be kept for one year.
22. **The construction work should be completed within two months of receipt of work order.**
23. Incase the work is not completed within the stipulated time frame, liquidated charges at the rate of 1% per week will be imposed on the Contractor subject to maximum of 10% of contract value. This amount will be adjusted from the bill of the Contractor.
24. The competent authority doesn't bind to accept the lowest or any other tender and reserves right to reject any or all the tenders received without the assignment of a person.
25. The Contractor shall submit minimum four progress report during the execution of work. This report shall be prepared in direct relation to the time stated in the contract documents for completion of items of work. A separate report will be given by the Contractor be made in writing by the Contractor.

Signature of Contractor



Signature of Principal
Army Public School
New Cantt Allahabad

26. Terms of Payments

- (a) 20% of total contract amount will be paid after completion of Plinth beam including all foundation work and earth filling of ground floor.
- (b) 15% of total contract amount will be paid after completion of work up to roof level including casting of columns, Brick work etc of Ground Floor.
- (c) 25% of total contract amount will be paid after completion of Sheet roofing work including fabrication of truss etc.
- (d) 20% of total contract amount will be paid after completion of flooring, plastering, electrification, fitting of wood work including windows, doors & cabinet.etc.
- (e) 10% of total contract amount will be paid after completion of all works including lighting, finishing like painting, white washing etc.
- (f) 5% of total contract amount will be paid after checking and satisfactory report by BOO during taking over of building.
- (g) Balance 5% of total contract amount shall be paid after completion of defect liability period of contract i.e. one year after successful completion of the work and rectification of defects, if noticed during the defect liability period.

In case of any dispute, the decision given by the Management /Principal will be final and binding.

Signature of Contractor



Signature of Principal
Army Public School
New Cantt Allahabad

PART V - DETAILED SPECIFICATIONS OF BUILDING WORK

1. **Earth Work**

- (a) All layout work with proper bench marking of center line's of columns.
- (b) Excavation of earth for trenches to construct footing as per details and size and refilling of trenches with excavated earth.
- (c) Anti termite in foundation before preparation of foundation bed.
- (d) Earth filling of plinth floor area and deep watering, compaction, Leveling etc.

2. **Anti-Termite Treatment**

- (a) Providing and injecting chemical emulsion for constructional anti-termite treatment and creating a chemical barrier under and all-around the column pit, walls trenches, excavation top surface of plinth filling junction wall and floor along the external perimeter of binding expansion joints, surrounding of pipes and conduit etc.
- (b) Chloropyriphos solution shall be used in 1:19 mix proportion (1 Liter Chemical:19 Liter water) in foundation trenches, plinth floor area, apron all around the building etc. as per detail and direction.
- (c) 5 liters of chloropyriphos solution in per Sq.m. area of foundation and 7.5 liters of chloropyriphos per sq.m. of Plinth floor area shall be used.

3. **Foundation Base**.150 mm thick foundation base in P.C.C. 1 : 4: 8 type D-2 (1 cement : 4 course sand : 8 graded stone aggregate 40mm nominal size stone ballast) in trenches, well compacted.

4. **R.C.C. Work & Sheet Roofing**

- (a) The foundation, columns, all level beams, chajjas, slabs etc. shall be of R.C.C. The design mix of concrete shall be M -25 (design mix) and as per the details and direction.
- (b) Material used in R.C.C. foundation, column, all level beams, Slabs, chajjas and other places shall be approved by the Architect or Engineer-in-Charge.
- (c) The mix proportion of cement, course sand, Aggregate for R.C.C. works shall be M -25 (design mix) and as per design details and direction.



Signature of Contractor

Signature of Principal
Army Public School
New Cantt Allahabad

- (d) Mechanical mixture machine and vibrator shall be used for any type and quantity of R.C.C. work at any level.
- (e) The P.P.C. cement of approved make shall be used confirming all IS Code. Make of Cement : ACC/JP/Birla
- (f) Provide form work and plywood shuttering for R.C.C. columns, slabs and beams as per design, details and direction.
- (g) The T.M.T. mild steel bars shall be used in R.C.C. work confirming all I.S. Codes.
- (h) Providing binding, bending, cutting, placing, lifting of all type of mild steel reinforcement for R.C.C. or other work.
- (j) Make and size of mild steel reinforcement used for R.C.C. or other work shall be approved by Architect or Engineer in charge, confirming all IS code.
- (k) Proper water curing of all R.C.C. work up to seven days from the date of casting regularly.
- (l) Quality of course sand and 20 mm size granite quartz aggregate shall be used as approved by Architect or Engineer Incharge.
- (m) Fabrication, Supply & Fixing truss work / m.s. pipe as per design, purlins, rafters and trusses will be ISI mark M.S.members with priming , painting and fixing all complete **as per the design, drawing, direction and details specification.**
- (n) Supply and fixing of color coated Aluminum –ZincAlloy coated steel (Aluminum – around 55% & Zinc -43%) rib profile sheets of 0.50 mm thick (TCT) having effective width 1000 mm +/- 10 mm, crest 25-32 mm and 200-250 mm pitch C/c with male female side laps and anti-siphoning features at male end, minimum Yield strength 550 MPA and confirming standards AS 1397 , ASTM A 792 in approved color and make including accessories such as Gutter Flashing, ridge pieces, barge boards, Crimped curves and with nylon coated self-tapping / self-drilling screws with EPDM washers etc., all works complete as per drawings, specifications and instructions of Engineer in charge. Rate includes cost of all materials against supply, Carriage Erection, Installation for roofing at all heights upto 13.00 m above from Ground level, labour, tools & plants and all other incidental charges etc complete. (Payment will be done on covered area basis) **as per the design, drawing, direction and details specification.**

Signature of Contractor

Signature of Principal
Army Public School
New Cantt Allahabad

5. **Brick Work in Foundation, Plinth and Super Structure etc.**

- (a) Provide and construct 230 mm thick brick wall in 1: 6 cement, medium sand, mix mortar with first class locally available bricks in foundation, plinth wall in super structure wall etc. as per details and direction.
- (b) Provide and constructed 115mm thick (4.5") brick work in 1: 4 cement, medium sand mortar in super structure with 2 Nos. 6mm dia MS bars at every 8 coarse of brick work, as per details and direction.
- (c) Provide and prepare all type of scaffolding work and other tools and plants for proper completion for brick work as per direction.
- (d) Proper water curing all type of brick masonry work up to seven days from the date of construction
- (e) The quality of all type of brick, cement, sand etc shall be confirming IS code and approved by the Architect or Engineer in charge.

6. **Plastering Work**

- (a) 15 mm thick cement sand plastering work on walls ceiling, beams, columns etc inside and outside of the building as per direction.
- (b) Provide 10 mm wide groove in plaster at every joints of beam, and columns with brick work.
- (c) All the plaster edges shall be in plumb line and sharp.
- (c) Plastering on ceiling and external exposed surface shall be in 1:4 cement, medium sand mortar mix as per specified thickness.
- (d) Internal plastering shall be in 1:4 cement, medium sand mix mortar as per specified thickness.

7. **Form Work, Shuttering, Centering, Scaffolding Work.**

- (a) Provide, prepare all type of plywood/ steel form work for R.C.C. columns, footings, etc.
- (b) Provide & prepare all type of plywood shuttering and centering for R.C.C. beams at any level R.C.C. slab at any level as per design and details.
- (c) Provide and prepare all type of scaffolding for all type of work as per requirement and direction.

Signature of Contractor

Signature of Principal
Army Public School
New CanttAllahabad

8. **Damp Proof Course**

- (a) Provide and construct 40 mm thick D.P.C. on entire top surface of plinth beam and wall with recommended water proof chemical as per detail and direction.
- (b) The damp proof coarse shall be casted with P.C.C. 1:2:4 type B-O concrete mix using 12.5 mm size stone aggregate.
- (c) The water proof chemical used for D.P.C. shall be confirm IS code and the proportion or dosage of chemical as described by make or brand.
- (d) The make or brand of water proof chemical shall be as per direction of Architect or Engineer In charge. Make :Ace proof/ Ace/ Impermo

9. **Flooring and Skirting Work**

- (a) 52 mm thick cement concrete flooring with concrete hardener topping, under layer 40 mm thick cement concrete 1:2:4 (1 cement : 2 coarse sand : 4 graded stone aggregate 20 mm nominal size) and top layer 12mm thick cement hardener consisting of mix 1:2 (1 cement hardener mix: 2 graded stone aggregate 6 mm nominal size) by volume, hardening compound mixed @ 2 litre per 50 kg of cement or as per manufacturer's specifications. This includes cost of cement slurry, but excluding the cost of nosing of steps etc. complete, **as per the drawing, details, direction and details specification.**
- (b) Cement plaster skirting up to 30 cm height, with cement mortar 1:3 (1 cement : 3 coarse sand), finished with a floating coat of neat cement. **as per the drawing, details, direction and details specification.**

10. **Doors & Windows.** All Material used in work shall be of approved make, brand and confirming IS code.

- (a) Providing and fixing of all door-frame, windows frames, door shutter etc.
- (b) All door frames shall be made of mild steel angle section 40 mm x 40 mm x 6 mm with grill on ventilators as per details and design.
- (c) All windows shall be sliding type made of color Coated Aluminum Windows with aluminum grill and 5mm thick clear transparent glass and fixed with stainless steel fly/mosquito proof jali as per design details and direction.
- (c) Provide and fixing 35 mm thick flush door with all GI fastener, fixtures and accessories of heavy quality approved make, size, shape, design, colour and confirming IS code.



Signature of Contractor

Signature of Principal
Army Public School
New Cantt Allahabad

11. **Wooden Cabinet** Providing and fixing Pre-laminated HDHMR Board in shelves with screws and fittings wherever required, edges to be covered with teak wood bead.
12. **Painting Work**. All Material use in painting work shall be of approved make, shade, colour, texture and confirming IS code.

(a) **In Internal Surface**

- (i) Providing and painting one coat of white cement of J.K. white cement or Birla white cement on wall and Ceiling surface as a Primer coat use 3.84 kg white cement for per 10 Sq.m. of surface including supply all tools plants etc for proper completion of work.
- (ii) Providing and applying **Birla white or J.K. white wall care make putty** on wall and Ceiling surface in two coats including rubbing and smoothing the surface properly to make in uniform and even including supply of all tools and plants for proper completion of work.
- (iii) Providing and painting one coat of primer over the putty finished surface.
- (iv) Providing and painting in two coats oil bound distemper over the wall and ceiling surface, of approved brand, colour, shade confirming IS code, as per detail and direction of Architect or Engineer Incharge.

(b) **In External Surface**

- (i) Providing and painting one coat of white cement of J.K. white cement or Birla white cement as a Primer coat use 3.84 kg white cement for per 10 Sq.m. of surface including supply all tools plants etc for proper completion of work.
- (ii) Providing and painting water proof super snowcem made cement base paint in 2 coats over the one coat of primer coated wall plastered surface of approved colour, shade, confirming IS code as per detail and direction.
- (iii) Provide and painting with two coat synthetic enamel paint over one coat red oxide primer on mild steel door frame "Z-Section window all grill and railing etc. of approved make and colouretc, as per direction.

Signature of Contractor



Signature of Principal
Army Public School
New Cantt Allahabad

- (iv) Providing and painting Asian Paint or Nerolac Made enamel paint of approved colour and shade in two coats on mild steel door frame Z section window grill and railing etc. as per details and design.
- (v) Providing and painting Asian Paint or Nerolac made wood primer and enamel paint in two coats of approved colour, shade as per details and direction.

13. **Electrical Work**

- (a) All material used for electrical work shall confirm the IS code. **as per details, drawing and directions**
- (b) Providing, laying and fixing of Electrical fan boxes and P.V.C. 25mm dia. Electrical Concealed conduits in slab and walls of approved make as per the electrical design details and direction and confirming IS code.
- (c) Providing and fixing of electrical 25mm dia. P.V.C. conduits in wall for concealed electrical circuit wiring as per the details and direction. The P.V.C. pipe shall be of approved make and confirming IS code.
- (d) Providing and laying copper wiring in electrical circuit of approved make and size confirming IS code :-
 - (i) All light and fan circuit wiring shall be with 1.5 Sq.mm. copper wire and 1.5 Sq.mm. copper earth wire. The wire shall be of approved make and confirming IS code. Six ceiling fan and tube lights will be fitted in each class rooms.
 - (ii) All power point circuit wiring shall be with 2.5 Sq.mm. copper wire and 1.5 sq.mm. copper earth wire. The wire shall be of approved make and confirming IS code.
 - (iii) Providing and fixing 5AMP, 15 AMP electrical switches and socket in circuits of approved make design, shape, colour and confirming I.S. code.
 - (iv) The location and numbers of switches boards, power points, tube light points, fan points etc shall be as per details drawing and direction.
- (e) Providing, fixing and making distribution board for electrical supply to all circuits with using M.C.B. & E.C.B. etc. of approved make confirming IS code.
- (f) Providing laying, electrical connection to distribution board with outdoor main electrical supply.



Signature of Contractor

Signature of Principal
Army Public School
New Cantt Allahabad

13. **Water Supply Work (as per requirement)**

- (a) Providing laying and fixing of concealed Prince or supreme made P.P.R. pipe for water supply from overhead water tank to all outlets at water closets, urinals, wash basin taps, etc and up to drinking water outlets, as per design and details direction. The material used shall confirming I.S. code (NA).
- (b) Providing laying, fixing and connecting 2 Nos. (i.e 1 No for ground floor and 1 No for first floor toilet block) 1000 liters Sintex or Polytuff make triple layer P.V.C. water tank over the terrace of toilet. **as per details, drawing and directions (NA).**
- (c) Providing laying and connecting water tank with main water supply line inside the school campus **(NA)..**
- (d) Providing and fixing Hind ware or Parry ware make, of approved colour design, water closet, wash basin as per details and direction. The material used shall be confirming I.S. Code **as per details, drawing and directions (NA).**
- (e) Two drinking water platforms with six water tap will be provided at two corners of the building. Drinking water platform will be properly made with tiles. Providing and fixing water taps, angle valve and other water supply and sanitary, fasteners, fixtures etc shall be of make Jaguar/ Marc plumber of approved design, shape, colour and confirming I.S. code. Size and design of platform of drinking water will be approved by the Principal APS New Cantt Allahabad at the time of execution of work. **as per details, drawing and directions (NA).**
- (f) Providing and constructing inspection chamber in required No & size at recommended location **as per details, drawing and directions (NA)..**
- (g) Providing laying, fixing and connecting 150 mm dia P.V.C. sewer line connection from outside located inspection chamber to septic tank and soak pit or existing sewer line. **(NA).**
- (h) Providing and construction of inspection chamber of required size and shape as per the design and detail inside and outside the building for proper sanitation. **(NA).**
- (j) Providing and fixing of supreme or prince make 150mm, 100mm, 75mm. dia. P.V.C. pipe, Nahani traps, other under floor arrangements to fix water closet, wash basins etc. for proper sanitation, from toilets and other water log area to inspection chamber located outside the building, as per the detail design and direction (as per requirement).
- (k) Providing and fixing of 100mm Dia. P.V.C. rain water pipe at required position as per details and direction.

Signature of Contractor



Signature of Principal
Army Public School
New Cantt Allahabad

14. **Plinth Protection.** Provide and construct 750 mm wide and 75 mm thick P.C.C. 1:2:4

type B -2 Bed as plinth protection over the 100 mm thick P.C.C. 1:4:8 type D -2 (1 Cement :4 Course Sand : 8 – 40 mm stone ballast) bed, as per details and direction all around the building.

15. **Approach Path**

(a) Providing and laying 3 meters wide with 60 mm thick M-35 grade interlocking tiles approach path over 100 mm thick PCC 1:4:8 type D -2 base at both end of building connected to inside campus road.

(b) The make design, colour, shape, pattern of Interlocking tiles shall be approved by Architect or Engineer in charge and confirming I.S. Code.

16. **Drawing and Design Charges.** Architectural, structural drawings and consultancy charges will be deducted from the contractor's payment @ 1.42% of total cost of project.

17. **Testing Charges.** All testing charges for brick, cement, material, design mix etc shall be paid by the Contractor without any extra cost to school.

Signature of Contractor



Signature of Principal
Army Public School
New Cantt Allahabad

PART VI :- DRAWING OF THE ATL LAB

Attached Drawings



Signature of Principal
Army Public School
New Cantt Allahabad

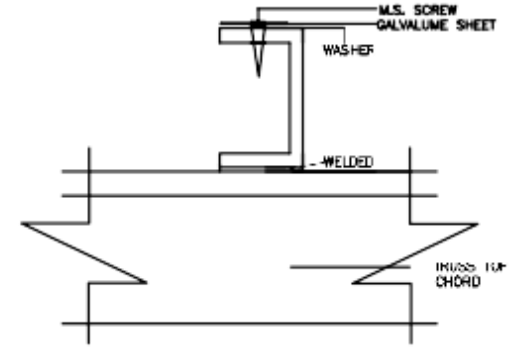
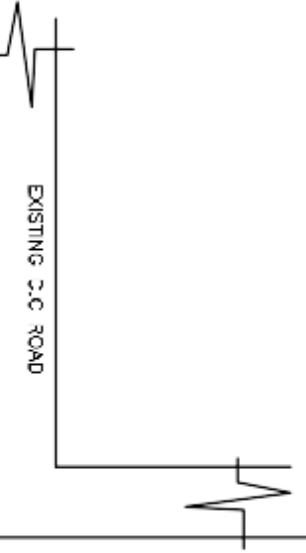
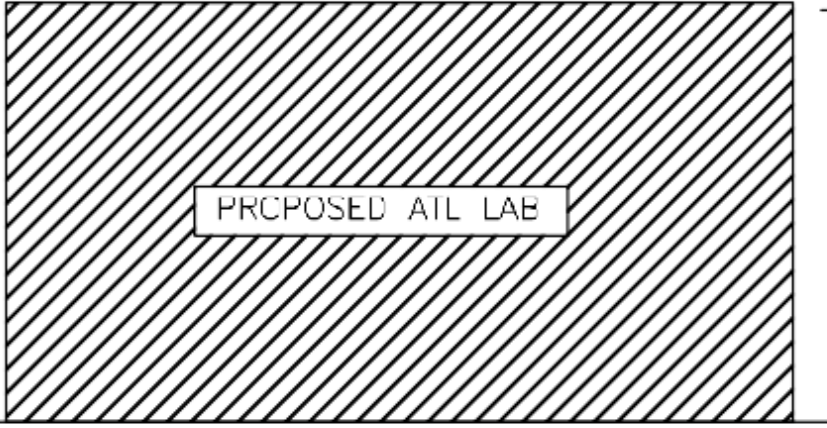

PURLIN AND SHEET JOINT DETAIL AT X

LOCATION PLAN OF PROPOSED ATL LAB

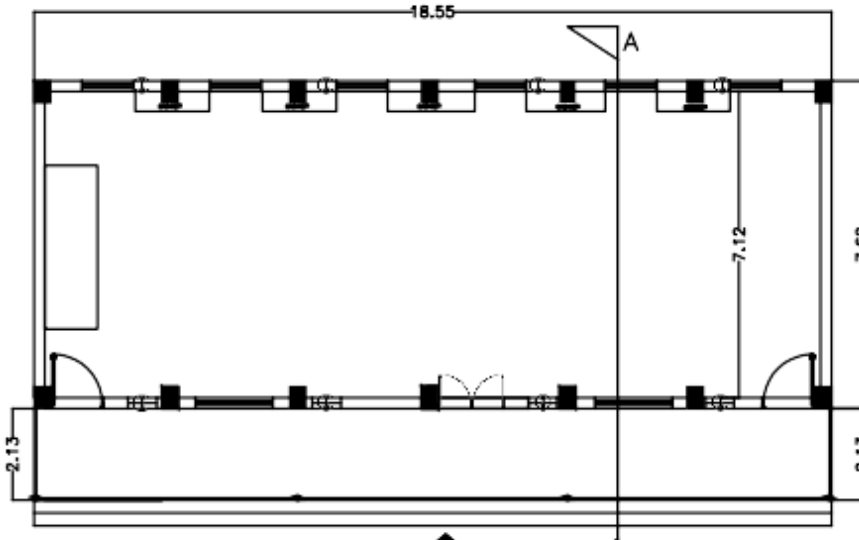

ATL LAB PLAN

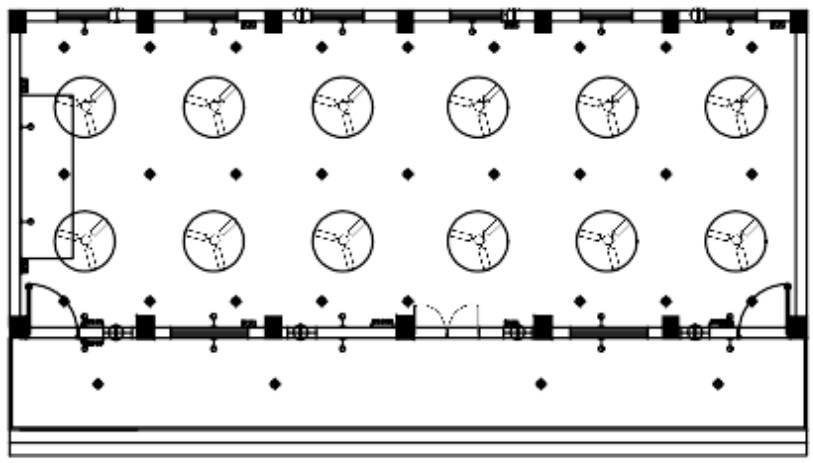

ELECTRICAL PLAN

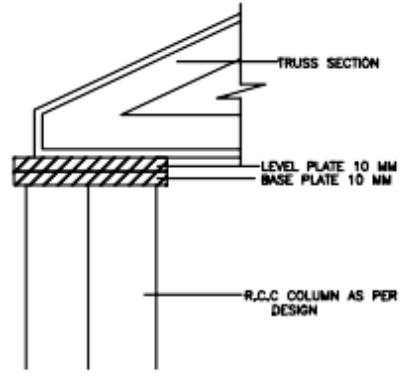
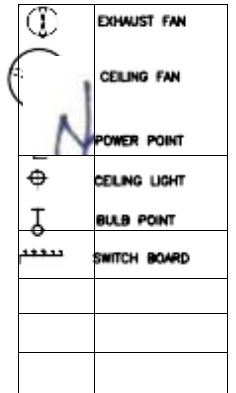

BASE PLATE SECTION AT Y

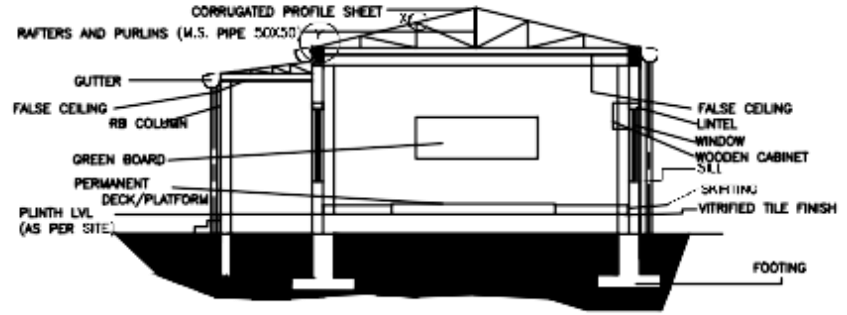

SECTION A-A'

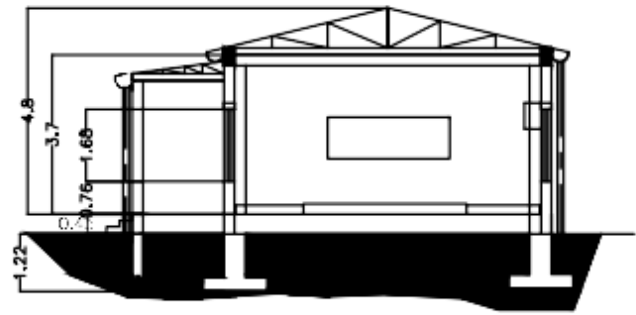

SECTION A-A'

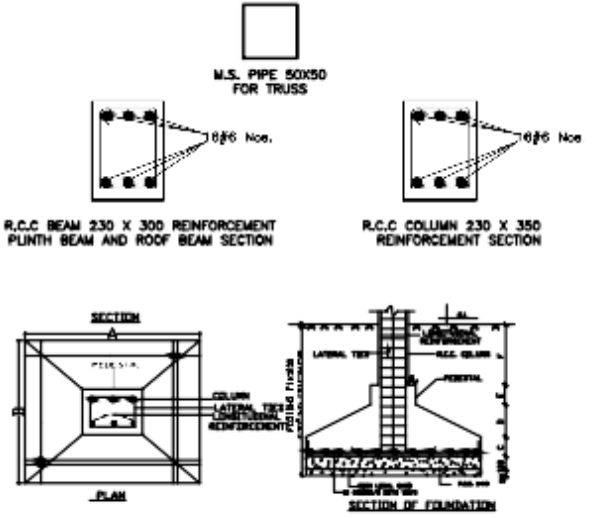

DETAILS N.T.S

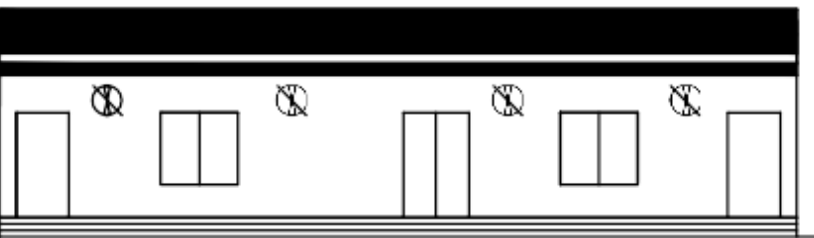

ELEVATION AT A

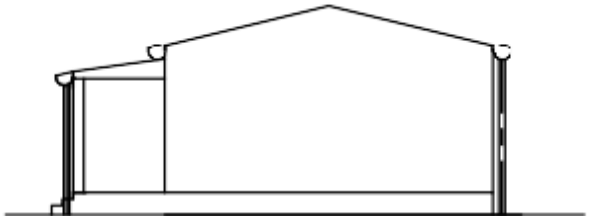

ELEVATION AT B

DRAWINGS

Reference: AR01

NOTES:
1. All dimensions in meter unless otherwise specified.
2. Figure dimensions shall be followed.
3. All dimensions shall be checked & verified before commencement of the work.
4. Discrepancy, if any, shall be brought to the notice of Architect in Charge and clarification obtained in writing prior to execution of the work.
5. All work shall be done as per latest Schedule of Specifications and relevant I.S. Code / B.S. Code.

NOTES:
All work including Supply and Fixing of several products shall be done as per Drawing, Details, Specifications and Direction of the consulting Architect.

NO.	DATE	BY	CHKD	SCALE

PROJECT: PROPOSED ATL LAB AT ARMY PUBLIC SCHOOL, NEW GAVLI, ALAHABAD

JOB TITLE:

PLAN, SECTION, ELEVATION, DETAILS

DATE:	PROJECT:	SCALE:

APS

01

CONSULTING FIRM: SRINATH TRICO BUILDCON LLP

Project: SALTAN TRIPATHI
Address: 10/10, Indira Nagar, Lucknow, U.P.
Contact: 9354648484, 9354648484
Email: srinathtrico@gmail.com

CHECKED BY: _____

FOR CLIENT: _____

FOR FIRM: _____

Subhakar